

# MAX™ Rectangular Wireless Charger

## INSTALLATION INSTRUCTIONS

Part#: IC-REC-XX-F

### PARTS / TOOLS NEEDED:

Wireless Charger & Pocket (optional)	Power Drill & Hole Saw	Router	Mounting Screws (not provided)	Marine Grade Splices (not provided)

### Safety/Installation Considerations

- Disconnect power before installing, adding or changing any component.
- To avoid a hazard to children, account for all parts and destroy all packing materials.
- *Electrical Specs:*  
Input voltage: 10-30V DC | Charging Capacity: Up to 10W (device limited) | Operating Current: 1A @ 13.6V | Standby Current: 0.03A
- Positive (+) outputs require a fuse if the attached wire leads are not rated to handle the max current.
- The charger has been designed to work with Qi compatible devices.
- The charger has been designed to charge and operate within the receiving device's thermal parameters. Low or high temperatures might cause the receiving device to change their charging behavior to regulate its temperature and preserve battery life. Typical temperature ranges are 0°C to 35°C (32°F to 95°F). When exceeding these operating temperatures, the phone and/or the charging device may temporarily stop charging to protect from overheating.
- The wireless charging module has been designed to be optimized with no case installed. If a thick phone case is added to the distance between the charger surface and the phone it may cause the device to not charge or to temporarily shut down to protect from over-heating.
- *Under mount version:* For strongest charging, the maximum distance between the charger and phone should not be more than 10mm. Larger distances will prevent the phone from charging properly.

1. Determine the installation location.

#### Surface Mount:

Make sure there is enough room to accommodate the mounting nut on the back and drill a 3" hole.

#### Under Mount:

A recessed pocket will need to be routed to a depth that is not more than 9mm. Use the template on page two to outline the pocket size needed.

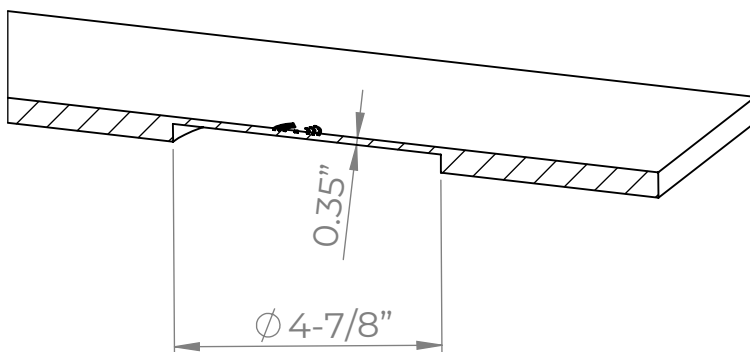

Under Mount



Surface Mount



3030 Corporate Grove Dr.  
Hudsonville, MI 49426  
Phone: 616.396.1355  
[itc-us.com](http://itc-us.com)

For warranty information please visit [www.itc-us.com/warranty-return-policy](http://www.itc-us.com/warranty-return-policy)  
DOC #: 710-00235 · Rev B · 07/11/24

2. **Surface Mount:**

Install the charger and tighten the provided plastic nut.

If installing the outer pocket, place the charger in the center of the pocket before tightening the nut.

**Under Mount:**

Remove the paper backing from the adhesive strip and press the charger to the surface. Screw the charger in, making sure the fasteners do not penetrate the top surface.

Surface Mount



Under Mount



3. Wire to the system following the diagram below.

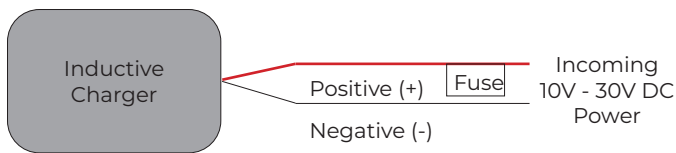

4. Under mount template

Router template

